



**FM200®  
MODEL FG & FD FIRE EXTINGUISHERS**

**INSTALLATION INSTRUCTIONS  
OWNER'S MANUAL**

**THIS MANUAL IS AN INTEGRAL PART OF THE SYSTEM AND AS SUCH, THE  
EXTINGUISHER MUST BE INSTALLED AND MAINTAINED ACCORDINGLY.**

**U.S. COAST GUARD APPROVED FM APPROVED  
No. 162.029/237/0**

**READ AND COMPLY WITH THESE INSTRUCTIONS, WARNINGS  
AND LIMITATIONS BEFORE INSTALLING.  
SUITABLE FOR USE FG MODELS: 0°F (-18°C) TO 130°F (54°C)  
FD MODELS: 20°F (-7°C) TO 130°F (54°C).**

**ALWAYS MAINTAIN THIS OWNER'S MANUAL NEARBY  
FOR OPERATOR REFERENCE.**

**OWNERS MANUAL PN: 123-194, REV. B  
PRINTED IN USA**



**SEA-FIRE MARINE  
DIVISION OF METALCRAFT, INC  
9331 A PHILADELPHIA ROAD  
BALTIMORE, MARYLAND 21237 USA  
TEL 410 687 5500 FAX 410 687 5503**

**SEA-FIRE EUROPE LTD  
UNIT 7. IO CENTRE. STEPHENSON ROAD  
FAREHAM, HAMPSHIRE  
PO15 5RU, UNITED KINGDOM  
PH: 44 (0) 1329 847225  
FX: 44 (0) 1329 847226**

Website: [www.sea-fire.com](http://www.sea-fire.com)

**Section 15 — Regulatory Information**

U.S. Federal Regulations: The components of this product are either on the TSCA Inventory or exempt (i.e. impurities, a polymer complying with the exemption rule at 40 CFR 723.250) from the Inventory.

State Regulations: None Known

**Section 16 — Other Information**

NFPA Codes:

Health:	1	Flammability:	0
Reactivity:	0	Other:	X

HMIS Codes:

Health:	1	Flammability:	0
Reactivity:	0	Protection:	X

**DISCLAIMER OF EXPRESSED AND IMPLIED WARRANTIES:**

Metalcraft/Sea-Fire Marine, Inc. has taken reasonable care in preparing this document, however, since the use of this information and the conditions of use of the product are not within the control of Metalcraft/Sea-Fire Marine, Inc., it is the user's obligation to determine the conditions of safe use of this product. The information in this document is offered with no warranties or representations as to accuracy or completeness and it is the responsibility of each individual to determine the suitability of the information for their particular purpose(s).

**Section 7 — Handling and Storage**

Handle, transport and store carefully and securely to avoid accidental knocking over or other severe physical impacts. Do not expose to direct heat sources. Do not over-pressurize.

**Section 8 — Exposure Controls/Personal Protection**

Respiratory: None

Protective Gloves: Leather gloves are recommended when handling cylinders.

Eye Protection: Eye protection is recommended when handling cylinders.

Other Protective Clothing or Equipment: Safety shoes are recommended when handling cylinders.

Work Hygienic Practices: Wash thoroughly after handling. Wash contaminated clothing before reuse.

**Section 9 — Physical & Chemical Properties**

Appearance: Colorless gas                      Physical State: Gas  
Odor: Odorless                                      Solubility in Water: 260 mg/L

**Section 10 — Stability and Reactivity**

Stability: Stable under normal conditions of handling and use.

Conditions to Avoid: None

**Section 11 — Toxicological Information**

VALUE (LD50 or LC50)	Animal	Routes	Components
>788.696 ppm/4H	Rat	Acute Inhalation	1.1.1.2.3.3.3 Heptafluoropropane

The human health hazards of this product are expected to be similar to other liquefied gases including N2, CO2, CFCs, HCFCs, and HBFCs. Therefore, direct eye or skin contact with the liquid or cold gas can cause chilling or possibly frostbite of exposed tissues. Inhalation of high concentrations can be harmful or fatal due to oxygen deprivation and/or heart irregularities (arrhythmias). Misuse of the products by deliberately inhaling high concentrations of this gas could cause death without warning. Persons with preexisting cardiac or central nervous system disorders may be more susceptible to effects of an overexposure.

**Section 12 — Ecological Information**

No ecological information is available.

**Section 13 — Disposal Considerations**

Dispose of waste and empty cylinders as allowed by current Local, State/Province, or Federal laws and regulations.

**Section 14 — Transport Information**

Proper Shipping Name: Heptafluoropropane

ID Number: UN3296

Hazard Class: 2.2

Packing Group: N/A

Labels: Non-flammable gas

Packing Instructions: 200

**WARNING**

CONCENTRATED AGENT AND BY-PRODUCT OF APPLICATION TO FIRE ARE TOXIC. AVOID BREATHING OF FUMES OR PROLONGED EXPOSURE. ACCIDENTAL DISCHARGE DURING HANDLING OR INSTALLATION MAY CAUSE SERIOUS INJURY. BEFORE ATTEMPTING TO INSTALL THIS DEVICE, READ AND COMPLY WITH INSTRUCTIONS, WARNINGS, AND LIMITATIONS CONTAINED IN THIS MANUAL. DO NOT LIFT, CARRY, OR HANDLE BY SENSOR VALVE/DETECTOR. THE SENSOR/VALVE DETECTOR IS VISUALLY DESCRIBED IN FIGURE 4 OF THIS MANUAL. DO NOT DROP. KEEP AWAY FROM HEAT. KEEP AWAY FROM CHILDREN.

**WARNING**

PRIOR TO PERFORMING MAINTENANCE WITHIN THE PROTECTED COMPARTMENT, ALWAYS INSTALL SAFETY PIN EXTINGUISHER SYSTEM TO AVOID ACCIDENTAL DISCHARGE. AT COMPLETION OF MAINTENANCE, REMOVE SAFETY PIN FROM TRIGGER ASSEMBLY, AND STORE IN HOLDING TIE LOCATED ON CYLINDER.

OWNER'S MANUAL & INSTALLATION GUIDE  
SEA-FIRE FM-200® AUTOMATIC FIRE EXTINGUISHER MANUAL: PART NO.123-194

## APPLICATION

FM-200® (CF3CHFCF3), the extinguishing agent, used in all Sea-Fire “FG” and “FD” series fire extinguishers, is a suitable EPA accepted alternate replacement for Halon. FM-200® is electrically nonconductive and residue free extinguishing agent that requires no cleanup.

These features and the versatility of design make the “FG” and “FD” series fire extinguisher lines ideal for a broad range of applications. These applications would include marine, commercial and industrial use where electrical or flammable liquids are the likely source of fire.

Sea-Fire “FG” and “FD” series have passed a rigid testing program and carry a Factory Mutual Research Corp. (FM) and United States Coast Guard (USCG) approval for fire suppression applications in marine pleasure craft, uninspected vessels, and Subchapter “T” inspected vessels, subject to the approval of the local Officer in Charge, Marine Inspection (OCMI). This would include many applications such as engine and generator rooms, electrical compartments, paint and flammable storage lockers.

Sea Fire “FG” and “FD” extinguishers are designed to induce a minimum atmospheric concentration of 8.7 percent within the protected compartment.\* The specification table in this manual lists the minimum and maximum approved compartment volume (size) allowable for each model. Volume can be determined by multiplying the compartment’s **length x width x height which equals the volume in cubic feet or meters (LxWxH=V)**.

\* Reference: NFPA 2001, UL2166.

**CAUTION: NEVER INSTALL A UNIT WITH A VOLUME RATING LESS THEN THE GROSS VOLUME OF THE COMPARTMENT TO BE PROTECTED. DO NOT DEDUCT FOR ENGINES, REMOVABLE TANKS OR OTHER EQUIPMENT.**

Exception: If the boat manufacturer has placed a permanently affixed label in the engine compartment specifying the gross volume less the volume of permanently installed tankage, then this volume may be used to determine the proper size extinguisher. Check the specification table for proper application before making installation.

## SYSTEM OPERATIONS

Sea-Fire units described in this manual are automatically actuated by a temperature sensor valve. Discharge will occur when the sensor valve temperature rises to the system activation point as shown in the specification table and on the label attached to each unit. Upon discharge, which is accompanied by a loud report and a hissing sound, the extinguishing agent (FM-200®) floods the compartment with an electrically nonconductive, noncorrosive vapor that stops the combustion process through both physical and chemical means. FM-200®, being an efficient heat transfer agent, literally removes heat energy from the fire to the extent that the combustion reaction cannot sustain itself.

**CAUTION: IN CASE OF EXTINGUISHER DISCHARGE, DO NOT RUSH TO OPEN THE PROTECTED COMPARTMENT. LET THE EXTINGUISHING AGENT WORK FOR SEVERAL MINUTES. HAVE A PORTABLE EXTINGUISHER AVAILABLE AND USE CARE WHEN OPENING THE COMPARTMENT.**

AVOID BREATHING FIRE RELATED FUMES OR VAPOR.

NOTE: It is important to retain the designed vapor concentration within the compartment to insure complete fire outage. Upon discharge, diesel engine(s) and all powered ventilation (blowers) must be shut down.

## PRESSURE SWITCH

Sea-Fire “FG” and “FD” series extinguishers are equipped with a factory installed pressure switch which is intended for cylinder pressure supervision and may also be used to control other electrical functions (engine shutdown, air exchange equipment etc.).

MSDS No. SF002

## MATERIAL SAFETY DATA SHEET

### Section 1 — Company and Chemical Identification

METALCRAFT/SEA-FIRE MARINE  
9331-A PHILADELPHIA ROAD  
BALTIMORE, MARYLAND 21237  
DATE:  
http://www.sea-fire.com

**EMERGENCY PHONE: 1-800-535-5053**  
PHONE: 1-800-445-7680  
NOVEMBER 10, 2005  
PRODUCT NAME: Fire Extinguisher

### Section 2 — Hazardous Ingredients/ Identity

C.A.S.	INGREDIENT NAME	OSHA PEL	ACGIH TLV	OSHA STEL
431890	HEPTAFLUOROPROPANE	NOT ESTAB.	NOT ESTAB.	NOT ESTAB.

### Section 3 — Hazard Identification

Emergency Overview: HEPTAFLUOROPROPANE is a colorless, odorless gas. Direct eye or skin contact with the liquid or cold gas can cause chilling or possibly frostbite of exposed tissues. Inhalation of high concentrations can be harmful or fatal due to oxygen deprivation and/or heart irregularities. Fire Extinguisher cylinders are pressurized. Although unlikely, a cylinder could be propelled and cause bodily injury and/or property damage if the valve is broken due to improper handling or storage.

### Section 4 — First Aid Measures

Skin contact: Flush with water, treat for frostbite if necessary by gently warming affected areas. Consult a physician.

Eye contact: Immediately flush eyes with plenty of water for at least 15 minutes. Consult an ophthalmologist.

Inhalation: Remove victim(s) to fresh air, as quickly as possible. If not breathing, qualified personnel should administer artificial respiration. Get medical attention. If breathing is difficult, administer oxygen.

Ingestion: No first aid should be needed. Not considered a potential route of exposure.

### Section 5 — Fire Fighting Measures

Flammability: Not flammable.

Conditions of flammability: Will not burn.

Extinguishing media: Use appropriate extinguishing media for surrounding fire.

Keep cylinders cool with water spray applied from a safe distance.

### Section 6 — Accidental Release Measures

Evacuate the area and ventilate. Do not enter areas where high concentrations may exist (especially confined or poorly ventilated areas) without appropriate protective equipment including a self-contained breathing apparatus.

## MANUAL DISCHARGE CABLE ASSEMBLY

MODEL	LENGTH	MODEL	LENGTH
SMAC-6	6 FT / 1.83 M	SMAC-20	20 FT / 6.10M
SMAC-8	8 FT / 2.43 M	SMAC-22	22 FT / 6.71 M
SMAC-10	10 FT / 3.05 M	SMAC-26	26 FT / 7.93 M
SMAC-12	12 FT / 3.66 M	SMAC-30	30 FT / 9.15M
SMAC-14	14 FT / 4.27 M	SMAC-36	36 FT / 10.98 M
SMAC-16	16 FT / 4.88 M	SMAC-40	40 FT / 12.20 M
SMAC-18	18 FT / 5.49 M	SMAC-D3	DUAL DISCHARGE CABLE ADAPTOR

NOTE: OTHER LENGTHS AVAILABLE, CONTACT FACTORY FOR DETAILS.

When using the pressure switch as an electrical disconnect for any equipment shutdown function, a means of overriding (bypassing, shunting) the pressure switch must be provided in order to return the affected equipment to an operational mode after extinguisher discharge has occurred. The pressure switch is a single pole single throw (SPST) type that is normally closed (NC) with the system in the charged condition. Discharge or loss of system pressure will release the contacts to an open state thereby cutting off any electrical current flow.

**NEVER USE PRESSURE SWITCH FOR ELECTRICAL LOADS OVER RATED CAPACITY.**

**SWITCH SPECIFICATIONS**  
4.0 AMPS AT 12 VDC    2.0 AMPS AT 28 VDC

For applications requiring larger load capacities, see optional equipment section in this manual or contact factory.

### ENGINES AND POWERED VENTILATION (BLOWERS)

#### DIESEL ENGINES

Continued operation of diesel engine(s) and or powered ventilation units will deplete the extinguishing agent and may cause a fire re-flash. **Diesel engine(s) must be automatically shutdown upon extinguisher discharge.**

Note: Power ventilation (blowers) that exceeds one air change per minute within the protected compartment must be automatically shutdown upon extinguisher discharge.\*

\* ABYC Requirement- Standard A-4

#### GASOLINE ENGINES

Shutdown may be accomplished by interruption of the electrical circuit between the ignition switch and the engine coils.

NOTE: Sea-Fire optional engine interrupt systems will automatically shutdown engines and powered ventilation upon discharge of the fire suppression system. They are available in 12 and 24-volt models with 3, 5 or 8 control circuits. Refer to optional equipment section in this manual.

**REMINDER: Sea-Fire systems shall be considered as supplementary to the number of portable fire extinguishers required on-board and are designed and intended for enclosed unoccupied compartment installations that are not subject to direct weather or water.**

## INSTALLATION

READ ENTIRE INSTRUCTION MANUAL AND CYLINDER NAMEPLATE PRIOR TO INSTALLATION.

These installation instructions are intended to cover most normal installations. Additional technical or application information can be obtained by contacting:

Sea-Fire Marine  
Baltimore, Maryland, USA  
Tel: 410 687 5500

or

Sea-Fire Europe LTD  
Unit 7. io Centre. Stephenson Road  
Fareham, Hampshire  
PO15 5RU, United Kingdom  
Tel: 44 (0) 1329 847225

Website: www.sea-fire.com

### CAUTION:

1. DO NOT INSTALL IN AN AREA DESIGNATED FOR OCCUPANCY.
2. ACCIDENTAL DISCHARGE MAY CAUSE SERIOUS INJURY.
3. HANDLE THE CYLINDER WITH EXTREME CARE.
4. WEAR EYE PROTECTION.
5. DO NOT LIFT OR CARRY CYLINDER BY THE MANIFOLD OR ACTUATOR COMPONENTS.
6. DO NOT ATTEMPT TO LOOSEN OR REMOVE ANY EXTINGUISHER COMPONENT.
7. DO NOT ATTACH SEA-FIRE EXTINGUISHER ON UNDERSIDE OF COVER OR COMPARTMENT HATCH THAT COULD BE THROWN CLEAR DUE TO POSSIBLE EXPLOSION.
8. DO NOT MOUNT WHERE AN ACCUMULATION OF STANDING WATER COULD BLOCK SENSOR OR CAUSE CORROSION.

### EXTINGUISHER INSTALLATION:

- Step 1** Carefully remove extinguisher from carton and visually check for damage in shipment.
- Step 2** To ensure that the extinguisher is operational, both the weight and pressure indicator must conform with the extinguisher specification as shown on the nameplate. Weigh extinguisher (less bracket) on an accurate calibrated scale before installing. Record date and weight on tag provided for this purpose.
- Step 3** Choose a location that is as high as possible on compartment bulkhead for mounting. Generally, it is preferred to locate the detector head near the area in which a fire is most likely to occur. This would be on the fuel line side of the engine, near the carburetor, or fuel pump. When mounting in a confined engine space, keep detector head away from exhaust manifold.
- Step 4** Loosen mounting bracket cylinder holding straps (**Figure 1**) and remove extinguisher from bracket. Although the sensor valve/detector is protected, care should be exercised to avoid striking the sensor valve/detector.

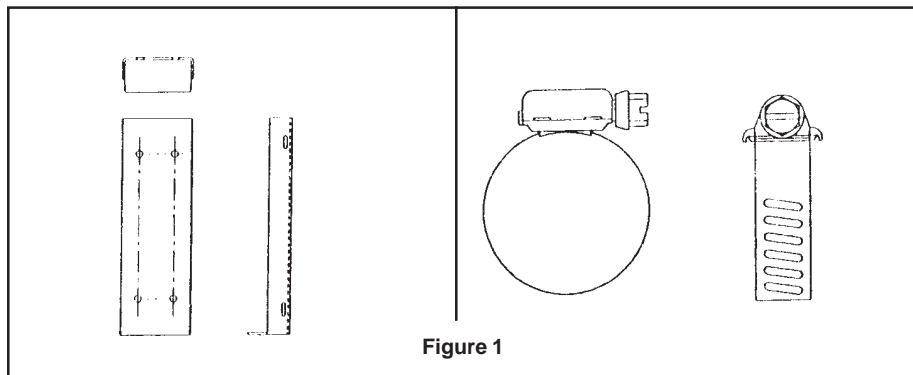

Figure 1

## SPECIFICATION TABLE SEA-FIRE "FD" SERIES AUTOMATIC FIRE EXTINGUISHERS 3AL/1000 CYLINDER

FD MODEL		AREA OF PROTECTION		MINIMUM FM-200®		MAXIMUM FM-200®		DIAMETER X HEIGHT	
AUTO	MAN/AUTO	CU.FT. RANGE	CU.M. RANGE	LBS	KG	LBS	KG	IN	MM
FD150A	FD150M	126-150	3.5-4.2	5.4	2.4	6.5	2.9	5.2x17.0	132x476
FD175A	FD175M	151-175	4.2-5.0	6.5	2.9	7.6	3.4	5.2x17.0	132x476
FD200A	FD200M	176-200	5.0-5.7	7.6	3.4	8.7	3.9	5.2x17.0	132x476
FD225A	FD225M	201-225	5.7-6.4	8.7	3.9	9.7	4.4	5.2x17.0	132x476
FD250A	FD250M	226-250	6.4-7.1	9.7	4.4	10.8	4.9	6.9x18.0	175x463
FD275A	FD275M	251-275	7.1-7.8	10.8	4.9	11.9	5.4	6.9x18.0	175x463
FD300A	FD300M	276-300	7.8-8.5	11.9	5.4	13.0	5.9	6.9x18.0	175x463
FD325A	FD325M	301-325	8.2-9.2	13.0	5.9	14.0	6.4	6.9x18.0	175x463
FD350A	FD350M	326-350	9.2-9.9	14.0	6.4	15.2	6.9	6.9x18.0	175x463
FD400A	FD400M	351-400	9.9-11.3	15.2	6.9	17.3	7.8	6.9x23.0	175x584
FD450A	FD450M	401-450	11.3-12.7	17.3	7.8	19.5	8.8	6.9x23.0	175x584
FD500A	FD500M	451-500	12.7-14.2	19.5	8.8	21.7	9.8	6.9x23.0	175x584
FD550A	FD550M	501-550	14.2-15.6	21.7	9.8	23.8	10.8	6.9x27.0	175x680
FD600A	FD600M	551-600	15.6-17.0	23.8	10.8	26.0	11.8	6.9x27.0	175x680
FD650A	FD650M	601-650	17.0-18.4	26.0	11.8	28.1	12.7	8.0x27.5	203x699
FD700A	FD700M	651-700	18.4-19.8	28.1	12.7	30.3	13.7	8.0x27.5	203x699
FD750A	FD750M	701-750	19.8-21.2	30.3	13.7	32.5	14.7	8.0x27.5	203x699
FD800A	FD800M	751-800	21.2-22.7	32.5	14.7	34.6	15.7	8.0x27.5	203x699
FD850A	FD850M	801-850	22.7-24.1	34.6	15.7	36.8	16.7	8.0x33.0	203x819
FD900A	FD900M	851-900	24.1-25.5	36.8	16.7	39.0	17.7	8.0x33.0	203x819
FD950A	FD950M	901-950	25.5-26.9	39.0	17.7	41.1	18.6	8.0x33.0	203x819
FD1000A	FD1000M	950-1000	26.9-28.3	41.1	18.6	43.3	19.6	8.0x33.0	203x819
V M O R U N T N I T L C I Y A N G L G	FD1050M	1001-1050	28.3-29.8	43.3	19.6	45.5	20.5	10x26	254x660
	FD1100M	1051-1100	29.8-31.1	45.5	20.5	47.6	21.6	10x26	254x660
	FD1150M	1101-1150	31.1-32.6	47.6	21.6	49.8	22.6	10x26	254x660
	FD1200M	1151-1200	32.6-34.0	49.8	22.6	52.0	23.6	10x26	254x660
	FD1250M	1201-1250	34.0-35.4	52.0	23.6	54.1	24.5	10x26	254x660
	FD1300M	1251-1300	35.4-36.8	54.1	24.5	56.3	25.5	10x26	254x660
	FD1350M	1301-1350	36.8-38.2	56.3	25.5	58.5	26.5	10x26	254x660
	FD1400M	1351-1400	38.2-39.6	58.5	26.5	60.6	27.5	10x26	254x660
	FD1450M	1401-1450	39.6-41.1	60.6	27.5	62.8	28.5	10x26	254x660
	FD1500M	1451-1500	41.1-42.5	62.8	28.5	65.0	29.5	10x26	254x660

OPERATING TEMPERATURE RANGE: 20° TO 130°F (-7° TO 54°C) FD MODELS

DISCHARGE TEMPERATURE: FD-150 thru FD-1500 175°F (79°C)

MODEL FD-150 thru FD-1000 APPROVED FOR VERTICAL OR HORIZONTAL MOUNTING

MODEL FD-1050 thru FD-1500 FOR VERTICAL MOUNTING ONLY

Cubic Feet = CU.FT.  
Cubic Meters = CU.M.  
Pounds = LBS

Kilograms = KG  
Inches = IN  
Millimeters = MM

**SPECIFICATION TABLE**  
**SEA-FIRE “FD” SERIES AUTOMATIC FIRE EXTINGUISHERS**  
**4B/360, 4BW/500 CYLINDERS**

FD MODEL		AREA OF PROTECTION		MINIMUM FM-200®		MAXIMUM FM-200®		DIAMETER X HEIGHT	
AUTO	MAN/AUTO	CU.FT. RANGE	CU.M. RANGE	LBS	KG	LBS	KG	IN	MM
FD150A	FD150M	126-150	3.5-4.2	5.4	2.4	6.5	2.9	5.1x17	130x432
FD175A	FD175M	151-175	4.2-5.0	6.5	2.9	7.6	3.4	5.1x17	130x432
FD200A	FD200M	176-200	5.0-5.7	7.6	3.4	8.7	3.9	5.1x17	130x432
FD225A	FD225M	201-225	5.7-6.4	8.7	3.9	9.7	4.4	6.1x17	160x432
FD250A	FD250M	226-250	6.4-7.1	9.7	4.4	10.8	4.9	6.1x17	160x432
FD275A	FD275M	251-275	7.1-7.8	10.8	4.9	11.9	5.4	6.1x17	160x432
FD300A	FD300M	276-300	7.8-8.5	11.9	5.4	13.0	5.9	6.1x17	160x432
FD325A	FD325M	301-325	8.2-9.2	13.0	5.9	14.0	6.4	6.1x17	160x432
FD350A	FD350M	326-350	9.2-9.9	14.0	6.4	15.2	6.9	6.1x17	160x432
FD400A	FD400M	351-400	9.9-11.3	15.2	6.9	17.3	7.8	7.1x18	180x457
FD450A	FD450M	401-450	11.3-12.7	17.3	7.8	19.5	8.8	7.1x18	180x457
FD500A	FD500M	451-500	12.7-14.2	19.5	8.8	21.7	9.8	7.1x18	180x457
FD550A	FD550M	501-550	14.2-15.6	21.7	9.8	23.8	10.8	7.1x18	180x457
FD600A	FD600M	551-600	15.6-17.0	23.8	10.8	26.0	11.8	8.1x22	206x559
FD650A	FD650M	601-650	17.0-18.4	26.0	11.8	28.1	12.7	8.1x22	206x559
FD700A	FD700M	651-700	18.4-19.8	28.1	12.7	30.3	13.7	8.1x22	206x559
FD750A	FD750M	701-750	19.8-21.2	30.3	13.7	32.5	14.7	8.1x22	206x559
FD800A	FD800M	751-800	21.2-22.7	32.5	14.7	34.6	15.7	8.1x33	206x838
FD850A	FD850M	801-850	22.7-24.1	34.6	15.7	36.8	16.7	8.1x33	206x838
FD900A	FD900M	851-900	24.1-25.5	36.8	16.7	39.0	17.7	8.1x33	206x838
FD950A	FD950M	901-950	25.5-26.9	39.0	17.7	41.1	18.6	8.1x33	206x838
FD1000A	FD1000M	950-1000	26.9-28.3	41.1	18.6	43.3	19.6	8.1x33	206x838
V M E O R U O T N N I T L C I Y A N L G	FD1050M	1001-1050	28.3-29.8	43.3	19.6	45.5	20.5	10x26	254x660
	FD1100M	1051-1100	29.8-31.1	45.5	20.5	47.6	21.6	10x26	254x660
	FD1150M	1101-1150	31.1-32.6	47.6	21.6	49.8	22.6	10x26	254x660
	FD1200M	1151-1200	32.6-34.0	49.8	22.6	52.0	23.6	10x26	254x660
	FD1250M	1201-1250	34.0-35.4	52.0	23.6	54.1	24.5	10x26	254x660
	FD1300M	1251-1300	35.4-36.8	54.1	24.5	56.3	25.5	10x26	254x660
	FD1350M	1301-1350	36.8-38.2	56.3	25.5	58.5	26.5	10x26	254x660
	FD1400M	1351-1400	38.2-39.6	58.5	26.5	60.6	27.5	10x26	254x660
FD1450M	1401-1450	39.6-41.1	60.6	27.5	62.8	28.5	10x26	254x660	
FD1500M	1451-1500	41.1-42.5	62.8	28.5	65.0	29.5	10x26	254x660	

OPERATING TEMPERATURE RANGE: 20° TO 130°F (-7° TO 54°C) FD MODELS

DISCHARGE TEMPERATURE: FD-150 thru FD-1500 175°F (79°C)

MODEL FD-150 thru FD-1000 APPROVED FOR VERTICAL OR HORIZONTAL MOUNTING

MODEL FD-1050 thru FD-1500 FOR VERTICAL MOUNTING ONLY

Cubic Feet = CU.FT.  
 Cubic Meters = CU.M.  
 Pounds = LBS

Kilograms = KG  
 Inches = IN  
 Millimeters = MM

**Step 5** Locate bracket in desired position (Vertical-Sensor Valve/Detector Head Up, or Horizontal, Figure 2). Using the bracket as a template, mark and drill holes in bulkhead and install bracket insuring that all bolts are thoroughly tight.

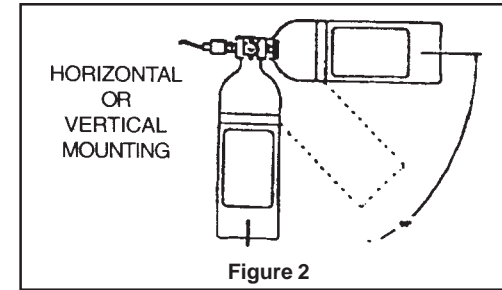

**WARNING:** When installing cylinder in horizontal position, the actuator (top of cylinder) must NEVER be lower than the bottom of the cylinder or proper discharge of agent will not occur (see Figure 2 above).

**MODELS FD1100 THRU FD1500 MUST BE INSTALLED VERTICAL ONLY**

**Step 6** Carefully attach cylinder to bracket. Sensor valve/Detector head should point towards engine or center of the compartment. Nameplate should be visible. Tighten bracket straps so that the cylinder body is firmly and securely held in place by its' bracket.

**CABLE ASSEMBLY INSTALLATION**

(for FG and FD systems with “M” designation - manual discharge capability: Model SMAC-XX is required.)

**CAUTION: TO PREVENT ACCIDENTAL DISCHARGE DURING CABLE INSTALLATION, VERIFY THAT THE MANUAL DISCHARGE LEVER SAFETY PIN IS PROPERLY INSTALLED (SEE FIGURE 6A OR 7C).**

- Step 1** Select the proper location.
- Manual discharge release handles should never be installed in the protected compartment.
  - Locate discharge handle at the helm station with full view and easy access by the operator.
  - The area selected must be structurally secure and provide at least twelve (12) inches (305mm) of clearance at the rear of the panel to facilitate cable hardware.
  - Do not install actuator cable in area where the possibility of physical abuse is likely. Where practical, follow the same cable path as installed by boat manufacturer.
  - The cumulative number of bends in the cable run must never exceed 360 degrees. This is equivalent to four (4) right (90°) angles. Use extreme care when bending cable to avoid kinking. Never form a bend with a radius of less than twelve (12) inches (305mm). Selection of the correct size Sea-Fire cable length will eliminate cable coil.

- Step 2** Mounting manual cable, faceplate, and release handle.
- Using the manual discharge faceplate as a template (**Figure 5**) mark and drill a 13/32 inch (10.4mm) hole. Install the manual release cable adhering to the guideline in Step 1 above.
  - Do not connect cable to the cylinder at this time.
  - Remove the protective backing from the faceplate. While aligning the holes, place even pressure upon the faceplate. To insure a good bond, the temperature should be in excess of 50°F (10°C).

- d. Following the diagram in **Figure 5**, install the nut and lock washer on the cable and insert the cable end through the panel and faceplate hole. Extend cable shaft out to its fullest and install ferrule by screwing onto the cable shaft end. Do not over tighten. Four or five turns are sufficient.
- e. Place rubber o-ring seal onto the cable shaft and install the release handle by screwing it onto the cable shaft. Do not tighten to the point where the pinhole in the handle will be obstructed.
- f. Push the handle into the ferrule. This will seat the o-ring seal. Align the pull pinholes in the handle and ferrule and insert the pull pin (**Figure 5**).
- g. Turn the handle so that the word **FIRE** is vertical. The handle can now be locked in position by tightening the nut behind the face plate panel.
- h. Temporarily remove pull pin and test cable operation. Cable must move freely without friction or binding. Reinstall pull pin and confirm that release handle is now locked in place.
- i. Attach the tamper resistant round plastic tie to the pull pin by passing tie through the pull pin ring and around the cable assembly. Insert the end of the tie into cable end and pull up snug. The tie provides a means of determining if manual discharge has occurred.
- j. Nylon cable ties should be used for cable securing. Fasten and support the cable on straight runs only. Do not secure at locations where cable forms a bend.

**CAUTION: DO NOT USE NYLON CABLE TIES AS TAMPER FOR PULL PIN.**

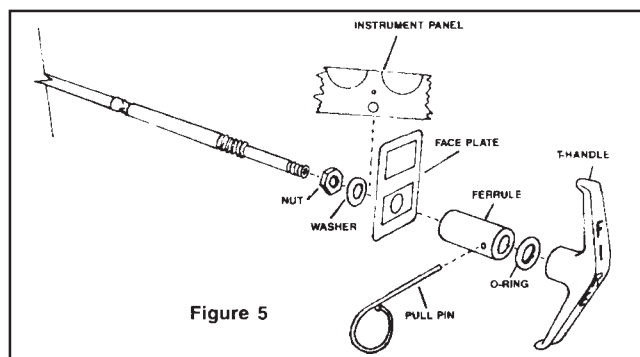

Figure 5

**CAUTION: ACCIDENTAL DISCHARGE DURING HANDLING OR INSTALLATION MAY CAUSE SERIOUS INJURY. DO NOT REMOVE FACTORY INSTALLED SAFETY PIN FROM CYLINDER SENSOR VALVE/DETECTOR UNTIL INSTALLATION IS COMPLETED AND CHECKED. WEAR EYE PROTECTION WHEN INSTALLING OR SERVICING THE SYSTEM.**

**Step 3** Connecting cable assembly to cylinder (**Figure 6 or 7**)

- a. Before attaching cable to the cylinder, check that the cylinder bracket is located correctly and firmly mounted.
- b. With the cylinder strapped in its bracket, pass the cable jacket ferrule completely through the hole in the cylinder manifold. This will allow the necessary cable flexibility needed for inserting the offset end of the flexible shaft into the actuator lever. After connecting the shaft and actuator lever, move the cable back and align the ferrule groove with the slot in the manifold. Insert the locking clip that is provided with cable assembly. The cable assembly must be locked to the manifold or accidental discharge can occur.
- c. Using care, remove the factory installed actuator lever safety pin from the cylinder. Store safety pin in the nylon retainer provided on the cylinder neck (**Figure 6 or 7**).
- d. The Sea-Fire manual/automatic extinguisher is now fully operational.

**SPECIFICATION TABLE  
SEA-FIRE "FG" SERIES AUTOMATIC FIRE EXTINGUISHERS  
DOT 39/500 CYLINDER**

MODEL		AREA OF PROTECTION		MINIMUM FM-200®		MAXIMUM FM-200®		DIAMETER X HEIGHT	
AUTO	MAN/AUTO	CU.FT. RANGE	CU.M. RANGE	LBS	KG	LBS	KG	IN	MM
FG25A	FG25M	0-25	0.0-0.7	-	-	1.0	0.5	2.5x9	64x229
FG50A	FG50M	26-50	0.7-1.4	1.0	0.5	2.2	1.0	3.1x12	79x305
FG75A	FG75M	51-75	1.4-2.1	2.2	1.0	3.3	1.5	3.1x15	79x381
FG100A	FG100M	76-100	2.1-2.8	3.3	1.5	4.4	2.0	3.5x15	89x381
FG125A	FG125M	101-125	2.8-3.5	4.4	2.0	5.4	2.4	4.1x16	104x406
FG150A	FG150M	126-150	3.5-4.2	5.4	2.4	6.5	2.9	4.1x16	104x406
FG175A	FG175M	151-175	4.2-5.0	6.5	2.9	7.6	3.4	5.1x16	130x406
FG200A	FG200M	176-200	5.0-5.7	7.6	3.4	8.7	3.9	5.1x16	130x406
FG225A	FG225M	201-225	5.7-6.4	8.7	3.9	9.7	4.4	5.1x16	130x406
FG240A	FG240M	226-240	6.4-6.8	9.7	4.4	10.4	4.7	5.1x16	130x406

OPERATING TEMPERATURE RANGE: 0° TO 130T (-18° TO 54°C)

DISCHARGE TEMPERATURE: FG-2S thru FG-75 212°F (100°C)  
FG-100thruFG-240 165°F (74°C)

ALL FG MODELS APPROVED FOR VERTICAL OR HORIZONTAL MOUNTING.

Cubic Feet = CU.FT.      Kilograms = KG  
Cubic Meters = CU.M.    Inches= IN  
Pounds = LBS              Millimeters = MM



### THREE (3) YEAR “FG” AND “FD” SERIES LIMITED WARRANTY

We warranty to the original retail purchaser, all SEA-FIRE extinguishers for a period of three (3) years after retail purchase against defective material and faulty workmanship. Any system found to be defective during the warranty period will be repaired if possible, or replaced free of charge if classified non-refillable (according to product label) upon the **prepaid** return of the defective system. Proof of purchase required, otherwise date of manufacturer on extinguisher label will apply. This warranty gives you specific legal rights which may vary by state or country.

**THE FOREGOING WARRANTY IS MADE IN LIEU OF ALL OTHER WARRANTIES WITH RESPECT TO THE SYSTEM INCLUDING ANY IMPLIED WARRANTY OF MERCHANTABILITY OR FITNESS FOR A PARTICULAR PURPOSE. NO PERSON IS AUTHORIZED TO GIVE ANY OTHER WARRANTY, OR TO ASSUME FOR SEA-FIRE MARINE ANY OTHER LIABILITY IN CONNECTION WITH THE SALE OR INSTALLATION OF ITS PRODUCTS. REPLACEMENT OF THE SYSTEM WILL BE THE SOLE REMEDY WITH RESPECT TO ANY LOSS OR DAMAGE TO PROPERTY. BUYER IS NOT RELYING ON SELLER’S JUDGMENT REGARDING BUYER’S PARTICULAR REQUIREMENTS AND BUYER HAS HAD AN OPPORTUNITY TO INSPECT THE PRODUCT TO BUYER’S SATISFACTION.**

#### CONDITIONS

All Sea-Fire products are tested after manufacture and shipped in perfect working order. Damage noted upon receipt of shipment should be addressed as a shipping claim, the filing of which is the sole responsibility of the consignee for which the total compensatory award will be limited to that appropriated by the carrier. Insured freight costs are the responsibility of the consignee. Missing component parts and damage noted upon installation are typically the result of mishandling during the installation process and will not qualify for warranty coverage. Incidents of accidental discharge are not indicative of product failure — heed product warnings to avoid injury and/or associated costs. **No returns will be processed without proper return authorization.**

#### OUT OF WARRANTY REPLACEMENTS/RECHARGES

**SEA-FIRE “FG”** Model Series cylinders comply with DOT Specification 39. These cylinders are **not refillable**. The discharged cylinder will be replaced with a comparable Sea-Fire extinguisher upon prepaid return of the discharged system for one-half of the current suggested list price.

**SEA-FIRE “FD”** Model Series cylinders comply with DOT Specification 4B/360, 4BW/500, and 3AL/1000 which allows discharged cylinder to be **refilled** and serviced. Reference cylinder label and making to determine the applicable DOT specification. The discharged extinguisher may be refilled upon the prepaid return of the discharged system. Contact factory or authorized dealer for detail.

#### RETURN TO:

##### UNITED STATES

SEA-FIRE MARINE Division of Metalcraft Inc.  
9331-A Philadelphia Road  
Baltimore, Maryland 21237 USA

##### EUROPE

SEA-FIRE EUROPE LTD  
Unit 7. io Centre. Stephenson Road  
Fareham, Hampshire  
PO15 5RU, United Kingdom  
PH: 44 (0) 1329 847225  
FX: 44 (0) 1329 847226

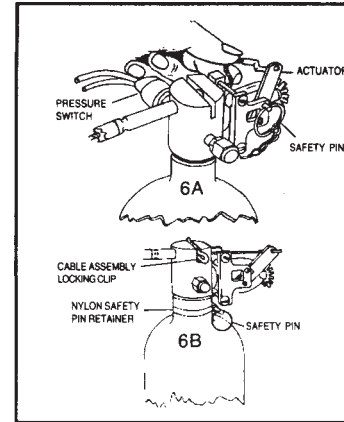

Figure 6

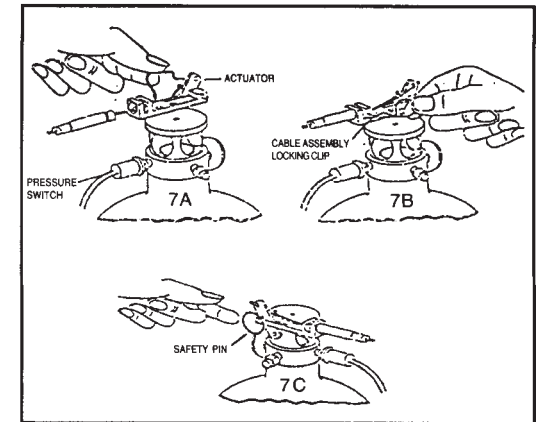

Figure 7

**REMINDER: ALWAYS INSTALL SAFETY PIN IN CYLINDER ACTUATOR LEVEL (FIGURE 6A or 7C) WHEN PERFORMING SERVICE OR MAINTENANCE ON SYSTEM. BE SURE TO REMOVE SAFETY PIN FROM ACTUATOR LEVER UPON COMPLETION OF SERVICING.**

#### INDICATOR LIGHT OPERATION

All Sea-Fire extinguishers approved for marine applications are packaged with an indicator light and escutcheon. The indicator light (unless replaced by another Sea-Fire method) must be installed for system supervision and operator awareness. When properly installed, activation of electrical power to the system will illuminate the light indicating normal charged condition. System discharge or loss of pressure will immediately extinguish the indicator light. In the event that the indicator light is not lit when power is applied, check for the following conditions:

1. Check pressure indicator gauge for proper range
2. Check fuse and indicator light and replace if defective (lamp replacements available from factory).
3. Check for loose electrical connections.
4. Remove and weigh system cylinder as described in **Maintenance Section** of the manual.

#### INDICATOR LIGHT INSTALLATION

Select a location at the helm on or near the console that is in full view of the helmsman. The location selected must have access for electrical wiring. Remove the adhesive protective cover from back of indicator escutcheon and attach. For proper adhesion, surface must be clean and dry and temperature must be above 50°F (10°C). Use the preformed escutcheon hole as a template and carefully drill a 5/16-inch (8 mm) hole. Insert indicator light wire through hole and seat light assembly by pressing clip into position. Indicator light is now ready for wiring (**see Figure 3**).

**CAUTION: PRIOR TO WIRING INDICATOR LIGHT TURN OFF ELECTRICAL POWER BY SWITCHING OFF CIRCUIT BREAKER, REMOVING FUSE OR DISCONNECTING POSITIVE BATTERY TERMINAL. FAILURE TO DISCONNECT ELECTRICAL POWER WHILE MAKING ELECTRICAL CONNECTION CAN RESULT IN INJURY FROM FIRE OR ELECTRICAL BURNS.**

The indicator light is rated for 12 VDC (contact factory for other voltages). Wire in accordance with the American Boating and Yacht Council standard E-9 “Direct Current Electrical System on Boats, copies of which may be obtained from ABYC, Edgewater, MD USA 21037, (410) 956-1050.

Supplies, which are not included with your Sea-Fire system and should be at hand before indicator light installation, are as follows:

1. Five (5) Ampere in-line fuse and holder
2. Sufficient length of insulated 16 AWG stranded wire.
3. Crimp on wire connectors.
4. Crimp pliers, hand tools.

Attach one wire lead from the in-line fuse to the ignition position on the starter switch. Connect other lead from the in-line fuse to the indicator light. Connect remaining indicator lead to one of the Sea-Fire cylinder pressure switch connector wires. Connect the remaining cylinder pressure switch lead to common ground, which may be the negative battery buss at the control panel, or directly to the engine block (see Figure 3).

**CAUTION: Electrical systems vary from vessel to vessel and these directions may not be applicable for your installation. Should you have any doubts of safely accomplishing this installation, contact a qualified marine electrician or SEA-FIRE MARINE USA @ 410 687 5500 for technical assistance.**

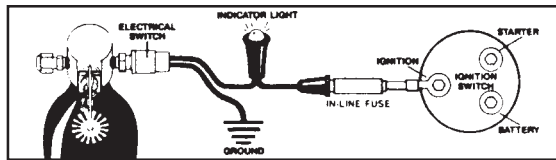

Figure 3

## SYSTEM MAINTENANCE

### Cylinder Inspection / Cylinder Testing

Model FG DOT 39 cylinders are non-reusable and do not require any testing.

Model FD DOT 4B, 4BW and 3AL cylinders are reusable and must be periodically tested. DOT 4B and 4BW cylinders may be inspected by an external visual inspection in accordance with Section 3 of CGA C-6, Standard for Visual Inspection of Steel Compressed Cylinders, and shall be performed every 5 years except the cylinders do not have to be emptied or stamped under pressure. Inspection shall be made by competent personnel and results noted on a permanent record tag. Alternatively the cylinders may be emptied and subjected to a hydrostatic test every 12 years in accordance with 49 CFR.

DOT 3AL cylinders must be emptied and subjected to a hydrostatic test every 12 years in accordance with 49 CFR.

**WARNING: DO NOT ATTEMPT TO DISASSEMBLE ANY PART OR COMPONENT OF THE EXTINGUISHER. THIS UNIT IS PRESSURIZED AND SERIOUS INJURY COULD RESULT. CONTACT THE FACTORY OR AN AUTHORIZED DEALER FOR SERVICE INFORMATION.**

Before operating, visually check to insure indicator light is operational, and cylinder pressure indicator is in the normal range. All fire suppression systems containing liquefied gas require periodic weighing to ensure a fully charged unit. Pressure gauges indicate the ability to discharge the agent but not the quantity of extinguishing agent. The cylinder (less bracket) must be weighed on at least a semiannual basis and be replaced immediately if gross weight has decreased by quantity noted on the specification label.

Never paint or obstruct the cylinder manifold or sensor valve/detector, as this will adversely affect its operating characteristic. **FD models are refillable**, see nameplate on cylinder for instructions and **OUT OF WARRANTY REPLACEMENTS/RECHARGES** section of this manual.

#### REMINDER:

- FREQUENTLY CHECK GAUGE FOR PROPER PRESSURE
- WEIGH CYLINDER TO INSURE AMPLE EXTINGUISHER AGENT

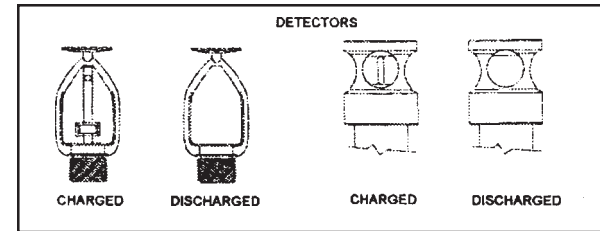

Figure 4

## LIMITATIONS

Sea-Fire "FG" and "FD" model series FM-200® automatic fire extinguishers are designed and tested to extinguish Class B (flammable liquid) fires in enclosed compartments only. Any open doors or hatches will allow discharging agent to escape and will seriously affect the ability of the agent to extinguish the fire.

Only one extinguisher may be used to protect a compartment. If more than one extinguisher is used to achieve the required amount of agent concentration, there is no guarantee that several extinguishers will actuate simultaneously as each extinguisher operates independently. Several extinguishers may be used only if each independent extinguisher is capable of protecting the entire volume of the compartment.

## OPTIONAL EQUIPMENT

**SDDA I** — Panel mounted visual/audible discharge alarm unit

**ESRS-2** — Panel mounted system status indicator with override switch for engine(s) restart. For use with the ESRS engine shutdown system as a replacement or add-on second helm station.

**ESRS III,V,VII** — Engine and powered ventilation (blower) shutdown system. Includes one circuit control unit and one panel mounted ESRS-2 visual/audible system status indicator with override switch for engine restart. Available with 3, 5, or 8 control circuits in 12 or 24 VDC models.

**ESRS-W/T III,V,VIII** — Same as ESRS-MARK shutdown system, but also includes a factory-installed nominal 20-second release timer on the engines control circuits. For use on diesel engines that shutdown through activation of a momentary device (i.e. push button, lever etc.).

**SFAB 12 (24)** — Discharge alarm bell 6" round 12 or 24 VDC models.

**ESEH-10** — 10 foot (3.05 meter) extender harness for use with ESRS systems.

**ESEH-30** — 30 foot (9.15 meter) extender harness for use with ESRS systems.

**Clean agent (FM-200\*) Portable Fire Extinguishers are also available.**  
Contact Sea-Fire or an authorized Sea-Fire dealer for details.